



SM18 Series Decoders:

SM18, SM18ST & SM18AR

Phoenix Sound Systems, Inc.

3514 West Liberty Road

Ann Arbor MI 48103

www.phoenixsound.com

phone: +1 (800) 651-2444

fax: +1 (734) 662-0809

e-mail: phoenixsound@phoenixsound.com

Table of Contents

Introduction.....	3
The SM18 Systems.....	4
Decoder Connections.....	4
Trigger Inputs.....	4
Programming Jack.....	4
Initial Checkout.....	5
The Basic Bench Test.....	5
Trigger Checkout.....	5
Default Trigger Assignments.....	5
DCC.....	6
DCC Function Defaults.....	6
Control Variables (DCC CV).....	7
Chart 1: Function Output Assignment (CV 35-46).....	8
Chart 2: CV29 NMRA Configuration Values.....	8
Standard Sounds and Effects.....	9
All Systems.....	9
Diesel Systems.....	9
Steam Systems.....	9
Triggered Sounds and Effects.....	10
All Systems.....	10
Diesel Only.....	10
Steam Only.....	10
General Installation Guidelines.....	11
The SM18: Bachmann Large Scale Socket.....	12
Plug In Installation.....	12
Speaker.....	12
K-27 Optical Chuff Jumper.....	12
The SM18ST: Screw Terminal.....	13
Installation.....	13
Speaker.....	13
The SM18AR: Aristocraft Socket.....	14
Mostly Plug In Installation.....	14
Speaker.....	14
Troubleshooting.....	15
LED Indicators.....	15
Technical Specifications.....	16
Access Jack Diagram.....	16
Appendix A: Wiring Diagrams.....	17
Basic DCC.....	17
CVP Airwire Converter.....	18
Crest Revolution DCC.....	19
Appendix B: The Computer Interface.....	20
Warranty.....	21

Introduction

Dear Model Railroading Friends,

Thank you for choosing Phoenix Sound Systems for your railroading enjoyment. The SM18 marks our first All-in-one sound and motor decoder for DCC Operation. The SM18 series of sound and motion decoders consists of three models, the SM18, SM18ST and SM18AR. Model specific information can be found in the corresponding section of this manual.

The SM18 is designed for simple plug in self installation in locomotives equipped with the Bachmann standard Large Scale Socket.

The SM18ST is equipped with screw terminals rather than pins for the Bachmann Large Scale Socket and is a general use configuration for locomotives without any form of socket.

The SM18AR is intended for Aristocraft locomotives and appears as something of a hybrid between the other two variants. The front end of the decoder – track inputs, motor output is a 12 pin connection to plug into the Aristocraft socket. The rear of the decoder consists of screw terminals for function outputs and a plug for the Aristocraft speaker socket.

The SM18 system, like all of our systems from the 2K2 onward, can be loaded and customized using a PC. You will need to upgrade your PC software to version *1.2.106* and ROM library files to version *R12* or newer to load and save SM18 compatible files.

The SM18 is protected against incorrect wiring and over-voltage gremlins. However, if you notice static electric sparks when you touch things you should ground yourself by touching something conductive before handling your board. Also be careful not to put the board on metal surfaces or model parts when powered. Basic electrical component handling precautions are always a good idea.

Happy Modeling.

The SM18 Systems

The SM18 system is a combined motor and sound decoder consisting of two stacked circuit boards. The smaller upper board handles sound while the larger lower board controls the motor, lighting and function outputs of the system. While the physical connection points vary among the SM18 models, the purpose and positions are the same across the series. Following is information common to all three SM18 variants, with type specific information and illustrations in their own sections of this guide.

Decoder Connections

DO NOT PLUG THIS MODEL INTO AN ARISTOCRAFT SOCKET LOCOMOTIVE. USE IN AN ARISTOCRAFT SOCKET VOIDS THE WARRANTY AND MAY RESULT IN DECODER FAILURE.

The Bachmann Large Scale Socket and Aristocraft socket may appear similar, in fact they have the same physical layout, however they are *not* interchangeable. The J2 connections on aristocraft sockets were never standardized and vary among the main aristocraft circuit board designs. For example, socket pin J2:1 may connect to the speaker on one but on another it may be connected to the decoder B+. Other decoders which may plug into the Aristocraft socket have no connections to the J2 pins.

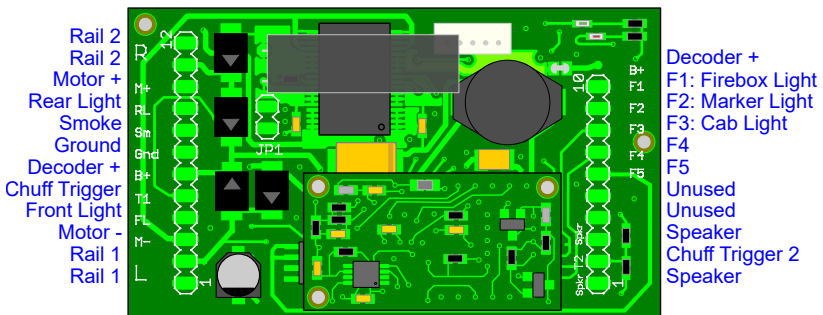

The Decoder + connection on J2 is only active on the -ST and -AR models.

Trigger Inputs

The SM18 series has two trigger inputs, intended for chuff synchronization. Trigger 1 is located at J1:5 and Trigger 2 at J2:2.

Programming Jack

The programming jack plugs into the upper circuit board at the back, between the two circuit boards as in the P14 system.

Initial Checkout

The Basic Bench Test

Each system is tested before shipping but we recommend that you hook things up and get comfortable with the components before installation.

For the SM18, simply plug the board in to the socket. For the SM18AR, plug the board into the socket and plug the speaker connector into the speaker socket. With the SM18ST, connect the track inputs to your track pickups and plug the speaker plug into the socket on the speaker leads; motor outputs should connect to the motor.

Diesels will rev up and down as you adjust your throttle. A steam engine system on the other hand will sit in idle (Coal Shoveling and Air Compressor play periodically) until it sees motion contacts connecting Trigger1 to ground. Each closure produces a Chuff. At first Chuff, the directional toots play and the bell starts ringing.

Steam can be configured to run off of DCC speed steps and diesel can be changed to look for wheel rotation. We initially set them up the way most modelers will use them.

Trigger Checkout

In order for steam to leave the idle state you will need a trigger connected to J1:1 and ground; you may wish to hook one up and experiment. Whenever the trigger (J1:1) is connected to the ground (J1:7) the system sees motion. The first closure should play the start toots and the starting bell.

If you will be using reed switches and track magnets or other triggers, such as Hall Effect devices, to trigger sounds you may wish to test them out before final installation. For reed switches, hook one lead to ground and the other to the desired trigger; sweep a magnet by the switch to trigger. The chart below shows the default trigger terminal assignments.

Default Trigger Assignments

Trigger (Location)	Diesel, Electric & Other	Steam
Trigger 1 (J2:2)	<unassigned>	Chuff
Trigger 2 (J2:2)	<unassigned>	Conventional: <unassigned> Articulated: Second Chuff

DCC

DCC Function Defaults

Address: 3

Function	Assigned Effect
F0	Headlight/Reverse Light Enable
F1	Bell
F2	Manual Whistle
F3	Output F1 [Bachmann Firebox Light]
F4	Smoke On/Off
F5	Output F3 [Bachmann Cab Lights]
F6	Output F4
F7	Volume Up
F8	Volume Down
F9	Blow Down
F10	Station Announcement
F11	Chatter
F12	Shutdown

Control Variables (DCC CV)

The SM18 firmware supports the following Control Variables, which can be modified through by programming, in service mode, ops mode or in the Phoenix Computer Interface CV Programmer.

Do NOT use OPS MODE FOR ADDRESS CHANGE COMMANDS

CV	Description	Default	Range
1	Short Address	3	0-99
2	Vstart	1	0-255
3	Acceleration Rate	10	0-255
4	Deceleration Rate	10	0-255
5	Vhigh	255	0-255
6	Vmid	128	0-255
7	Manufacturer Version # {Read Only}	18	n/a
8	Manufacturer ID {Read Only}	107	n/a
11	DCC Timeout (seconds) {Motor Control}	10	0-255
17	Long Address	192	0-255
18	Long Address	3	0-255
29	Configuration <i>(See Chart 2)</i>	6	0-255
35	Function F1 <i>(See Chart 1)</i>	0	0-8
36	Function F2 <i>(See Chart 1)</i>	0	0-8
37	Function F3 <i>(See Chart 1)</i>	3	0-8
38	Function F4 <i>(See Chart 1)</i>	8	0-8
39	Function F5 <i>(See Chart 1)</i>	1	0-8
40	Function F6 <i>(See Chart 1)</i>	2	0-8
41	Function F7 <i>(See Chart 1)</i>	0	0-8
42	Function F8 <i>(See Chart 1)</i>	0	0-8
43	Function F9 <i>(See Chart 1)</i>	0	0-8
44	Function F10 <i>(See Chart 1)</i>	0	0-8
45	Function F11 <i>(See Chart 1)</i>	0	0-8
46	Function F12 <i>(See Chart 1)</i>	0	0-8
49	0 = Speed from Triggers; ≠ 0, speed from DCC	0	0-255
50	The DCC Value where motion starts.	0	0-255

51	The DCC Rate (Speed vs. Throttle)	100	0-200
52	DCC Timeout (seconds) {Sound System}	10	0-255
53	Seconds in idle before shutdown. 0 = Never	0	0-300
65	Kick start	0	0-255
67-94	User Speed Table (<i>Disabled by default</i>)	-	0-255
224	Headlight Full Intensity (percentage)	100	0-100
225	Headlight Dim Intensity (percentage)	30	0-100
226	Auto-Dim Headlight Mode (Rule 17). Disabled = 0; Enabled ≠ 0	0	0-255
255	Motor Controller Firmware Version {Read Only}	82	n/a

Chart 1: Function Output Assignment (CV 35-46)

Value Description

1	Output F3: J2:8 [Cab Light - Bachmann Plug In]
2	Output F4: J2:7
3	Output F1: J2:10 [Firebox Light - Bachmann Plug In]
4	Output F2: J2:9 [Marker Light - Bachmann Plug In]
5	Output F5: J2:6
6 & 7	<i>Unused</i>
8	Smoke; J1:8

Chart 2: CV29 NMRA Configuration Values

Bit	Value	OFF (Value 0)	On
Bit 0	1	Normal Driving Direction	Reverse Driving Direction
Bit 1	2	14 Speed Steps	28/128 Speed Steps
Bit 2	4	Digital operation only	Digital & Analog Operation
Bit 3	8	<i>Unused By Phoenix Sound Systems Decoders</i>	
Bit 4	16	Internal Speed Curve	User Speed Table (CV67-CV94)
Bit 5	32	Short Address mode (CV1)	Long Address mode (CV 17/CV18)
Bit 6	64	<i>Reserved By NMRA for future use</i>	
Bit 7	128	<i>Decoder type, set as Multi-function (0), not user alterable</i>	

Standard Sounds and Effects

Most sounds play automatically based on train speed. Many sounds can also be set to play using designated trigger inputs. The following section describes the standard sound system configuration.

All Systems

Whistle/Horn: Toots when starting (2 forward, 3 reverse) and stopping (one toot). Crossing whistle sequence plays when you reach the Whistle/Horn play speed. You must slow down to at least 75% of the play speed in order to have it play again when you speed back up.

Bell: Plays when you first start moving and just before stopping. You must reach twice the bell stopping speed in order to replay the bell when stopping. The bell will not replay unless 35 seconds have elapsed since the last time it played.

Coupler Clank: Plays when you come to a stop in reverse; will not replay until you go forward and back up again.

Brake Screech: Plays just before stopping.

Diesel Systems

Air Pop: Plays periodically during idle. Also plays while moving in SFX.

Brake Release: Plays as the engine starts moving.

Compressor: Plays periodically during idle.

Steam Systems

Blow Down: A longer and heavier steam release that clears out the ashes/clinkers.

Steam Release: Plays after you come to a stop.

Generator: Basically runs all the time but the engineer will shut it down if the engine sits in idle for awhile. Comes back on when voltage approaches the start voltage.

Air-Pump: Plays in idle to maintain air pressure.

Air-Pump 2: A sustained compressor run that restores depleted air pressure.

Rod clank: Plays at slow speed.

Hiss: Plays at low speed, clears the cylinders of condensation from the steam.

Coal Shoveling: Plays periodically while engine sits at idle.

Injector: Forces water into the boiler. Plays periodically while engine sits at idle.

Triggered Sounds and Effects

The following section describes sounds which may be assigned to triggers or DCC functions. Of course, any sound can be assigned to a trigger or Function Button. See the tables on pages 5 and 6 for factory default trigger and DCC Function assignments.

All Systems

Tunnel Fade: This trigger causes the volume to fade down to a lower setting.

When the input is triggered again, the volume will come back to the prefade setting.

Doppler: In diesel, when you trigger this input, the next time the crossing horn plays it will go thorough the pitch shift that you hear as a train is speeding toward and then away from you. Doppler is speed sensitive. In steam, triggering this effect will cause the pitch of the chuff to shift as the engine approaches and a second triggering will cause the pitch to shift back to normal.

Working/Drifting: An effect that makes the locomotive sound like it is struggling with a heavy train or coasting into a station.

Diesel Only

Dynamic Brake: A triggered only sound. It is almost a tone which results from using diesel drive motors as generators.

Rev Up/Down: Causes the prime mover sound to go to the next/previous rev. The sound will return to the corresponding rev based upon speed changes.

Radio Defect (Hotbox) Detector: Plays a detector radio announcement randomly selected from a list. Can be triggered or set to play automatically.

Steam Only

Water Fill: In programmed mode the sound plays 10 seconds after trigger if the loco is stopped; in manual mode the sound plays when triggered.

Coal Loading: In programmed mode the sound plays 10 seconds after trigger if the loco is stopped; in manual mode the sound plays when triggered.

Mallet Mode: Plays a second set of chuffs, moving in and out of phase with the main chuff. *Only applicable in Autochuff mode; a second chuff trigger is available for use in triggered chuff mode.*

Second Chuff Trigger: Plays a second set of chuffs independent of the main chuff trigger.

General Installation Guidelines

Speaker – Use the largest speaker that can reasonably fit your available space.

For best acoustics, the speaker should be sealed to the floor so that sound going out the front of the speaker cannot easily get to the back side.

Access Jack – Unobtrusive but accessible. Typically in the floor of tenders and boxcars and on the fuel tanks of diesels. Many models have removable pieces, doors, etc. where you can mount these hidden from view.

Mounting the Decoder – Make sure that the circuit boards will not touch anything metal. The decoder may get warm enough to soften hot melt glue so we do not recommend it; do not use conductive silicon adhesive either.

Speed Sensor – You may need to experiment to get reliable triggering from a rotating axle with magnets on it. After mounting the magnets on the axle, hold the reed switch in various positions and hook something to the reed so you can tell when the switch is closed. An ohm meter with a beeper works great. You can point the reed switch directly at the axle/magnets but there will be less motion tolerance. With the magnets sweeping the side of the reed switch as shown a clearance of about 3/16" is usually right. If you are too close you may get extra closures—one as the magnet approaches, and one as it leaves.

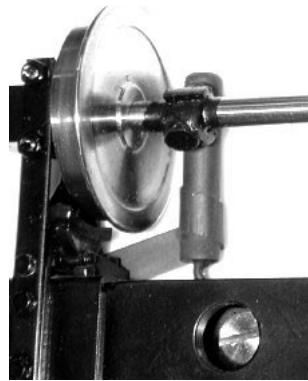

Mounting Hole Sizes – 1/4" hole for reed switches; 9/32" for access jack. Speaker depends upon type and location.

The SM18: Bachmann Large Scale Socket

Plug In Installation

Simply remove the appropriate cover piece of the locomotive (coal load on most and the central domes on the 2-6-6-2). Remove the Bachmann Dummy Board. Plug in the SM18 in the socket where the Dummy Board was located. Replace the locomotive cover. You are done. You may wish to add a mounting hole for the programming jack.

PLEASE NOTE THAT THE BACHMANN SOCKET ARRANGEMENT HAS DIFFERENT PIN COUNTS ON EACH END AND CAN ONLY BE INSERTED IN ONE ORIENTATION.

Speaker

Most Bachmann Socket equipped locomotives have the speaker factory installed. In the case of the K-27 and 2-6-6-2 there is a speaker mount but no speaker. These are sized for a 3 inch round speaker (Phoenix part number 820-770) which can then be wired to the solder pads on the locomotive circuit board labeled “speaker”.

K-27 Optical Chuff Jumper

The K-27 was the first Bachmann locomotive equipped with the optical chuff sensor; consequently following locomotives were fitted with a slightly different circuit to enhance the sensor response based upon the K-27 experience. As a result, when using the optical chuff sensor in the K-27 a jumper must be disabled on the SM18 base board. Simply lift the shunt off of the two pins it is jumping. We recommend putting the shunt back on only one of the pins so that it does not get misplaced. The jumper is located next to the large horizontal capacitor on the circuit board, roughly in line with the J1:8 and J1:9 positions, as shown below.

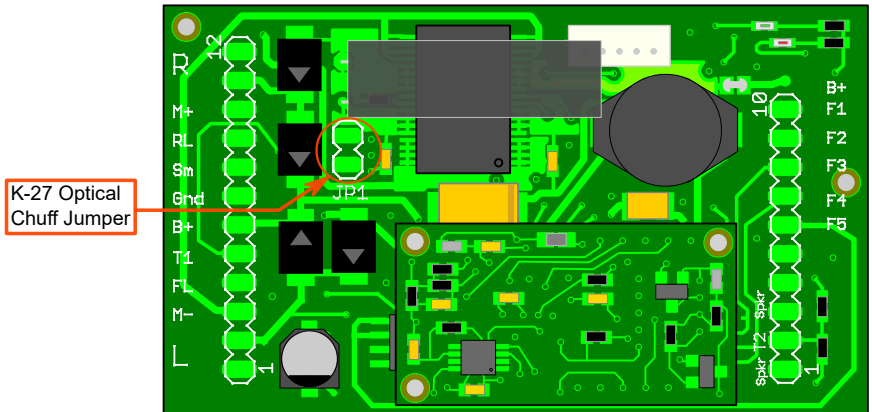

The SM18ST: Screw Terminal

Installation

Open the locomotive as required; location and access depends upon the locomotive, some steam simply require removing the tender load while most diesel require the shell to come off. All connections will need to be made between the track, motor and function outputs as desired. Basic wiring diagrams can be found in their own section of this manual.

Speaker

Appropriately sized speakers are available from Phoenix Sound Systems that are wired with the mating connector for the speaker lead from the SM18ST.



The SM18AR: Aristocraft Socket

Mostly Plug In Installation

Open the locomotive as required; location and access depends upon the locomotive, some steam simply require removing the tender load while most diesel require the shell to come off. Remove the jumper plug from the socket. Plug in the SM18AR in the socket where the jumper was located. Plug the speaker lead into the mating socket on the locomotive circuit board, often label “SPK”. Wire the screw terminals to the functions you wish to control. You are done. You may wish to add a mounting hole for the programming jack.

PLEASE NOTE THAT THE ARISTOCRAFT SOCKET WAS NEVER STANDARDIZED FOR THE J2 CONNECTOR. THEY DO NOT APPEAR TO BE CONSISTENT ACROSS LOCOMOTIVES NOR MATCH THE BACHMANN ARRANGEMENT.

USING AN SM18 FOR THE BACHMANN SOCKET INSTEAD OF AN SM18AR COULD RESULT IN DAMAGE TO THE DECODER AND OR THE LOCOMOTIVE OR ITS COMPONENT PARTS. ANY DAMAGE RESULTING FROM USING THE WRONG DECODER MODEL IS EXPLICITLY NOT COVERED UNDER WARRANTY.

Speaker

Nearly all Aristocraft locomotives have a speaker factory installed. In the case of these non sound-ready locomotives an appropriate speaker is available from Phoenix Sound Systems that is wired with the mating connector for the speaker lead from the SM18AR.

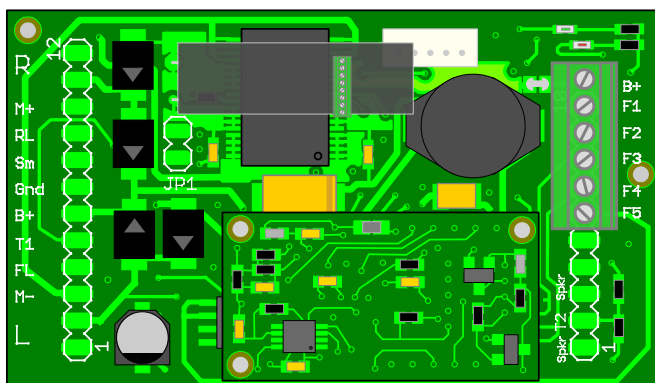

Troubleshooting

No DCC response and no sound – Start by rechecking the wiring to the track pick ups. A connection may have been missed or become loose.

No DCC response but idle sounds play – Check your DCC address. Also, verify that you have DCC on the track and not just a DC power source.

Motor runs but prime mover does not rev up – Make sure that you have not accidentally set the system for speed by triggers rather than DCC speed commands.

Motor does not respond but sounds and functions do – Check the wiring to the motor from the decoder, a connection may not be made. Verify that the DCC CVs 2, 5 & 6 have not been changed in error.

No Chuffing – If using a reed switch, that the magnets are within range. The wires coming from the trigger might be broken or loose. Engines with built-in contacts physical may require cleaning or oiling of the contacts. The K-27 Jumper may not be set properly. If you think you are in autochuff, you may actually be in triggered chuff mode with no trigger connected, verify the chuff trigger setting.

Erratic Chuffing – The axle magnets may not be mounted symmetrically. Also, if the reed switch is not mounted to the truck, the distance to the magnet might change during curves. The wires coming from the reed switch might be broken or loose. Engines with built-in contacts (Bachmann Spectrum) may require cleaning or oiling of the contacts. Contact Problems are the normal cause for faster than normal chuffing.

Whistle too frequent – The whistle plays based upon the speed reaching the whistle play speed threshold. If the train slows down in curves or at grades this may cause additional whistle triggering. Running at a slightly higher or slower speed may help. If a reed switch is used to blow the whistle, triggering may occur due to unexpected magnetic fields. Make sure your reed switch is not mounted too close to your speaker.

LED Indicators

SM18 units have two LEDs which indicate status of the system.

State	Status Description
<i>GREEN LED</i>	
Steady On	Good DC power, no DCC signal
Slow Blink	Valid DCC
Fast Flash	DCC Error / Bad packed indicator
<i>RED LED</i>	
Flash	Loss of DCC and or CAN signal

Technical Specifications

Length – 2.44in; 62 mm

Width – 1.42 in; 36 mm

Height, seated – 0.565 in; 14.35 (not including pins)

Maximum Track Volts – 30V.

Total Current – 5A.

Motor Current – 3A.

Amplifier – 3 Watts maximum.

Speaker Load – 4 Ohms or greater; two 8 Ohm speakers in parallel is fine.

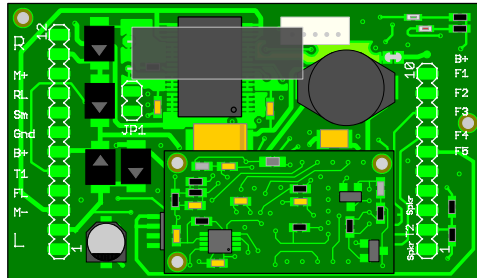

Access Jack Diagram

THE PLUG IS A STANDARD 2.5MM STEREO (TRS) PLUG. THE SUPPLIED JACK IS FULLY INSULATED FROM THE MOUNTING HOLE. OTHER 2.5MM JACKS MAY BE SUBSTITUTED – BUT MAKE SURE THAT THERE IS NO GROUND PATH BETWEEN THE COMMON TO ANY OF THE TRACK PICKUPS OR DECODER +

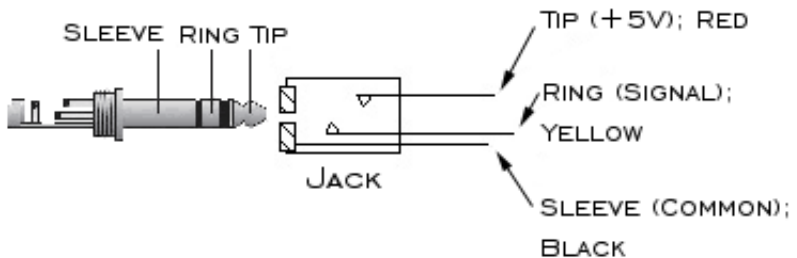

Appendix A: Wiring Diagrams

Basic DCC

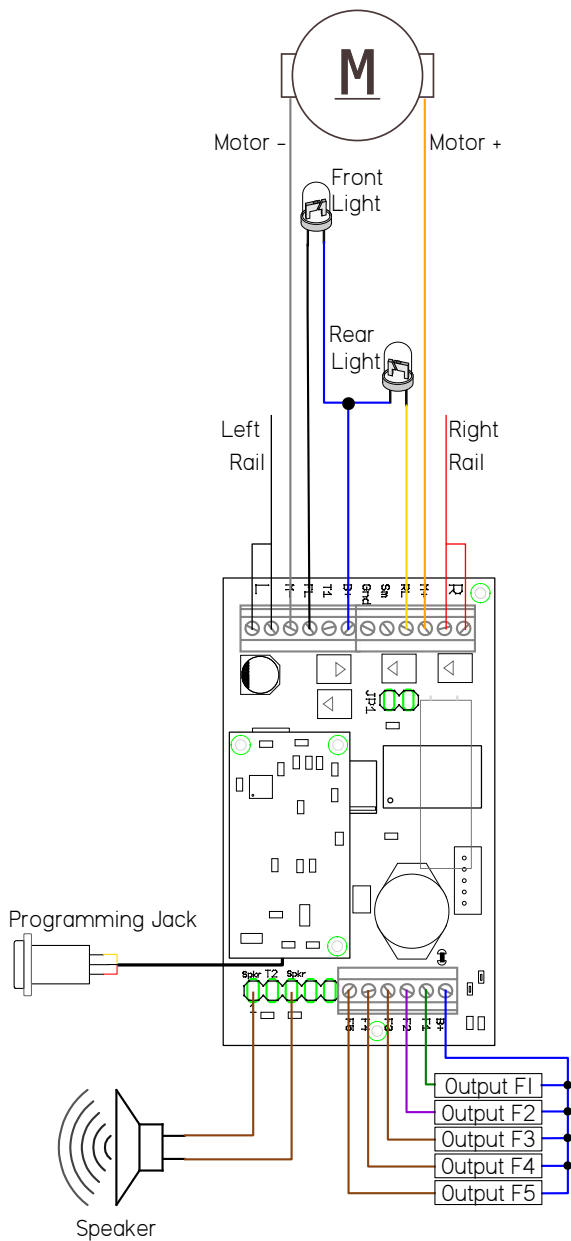

CVP Airwire Converter

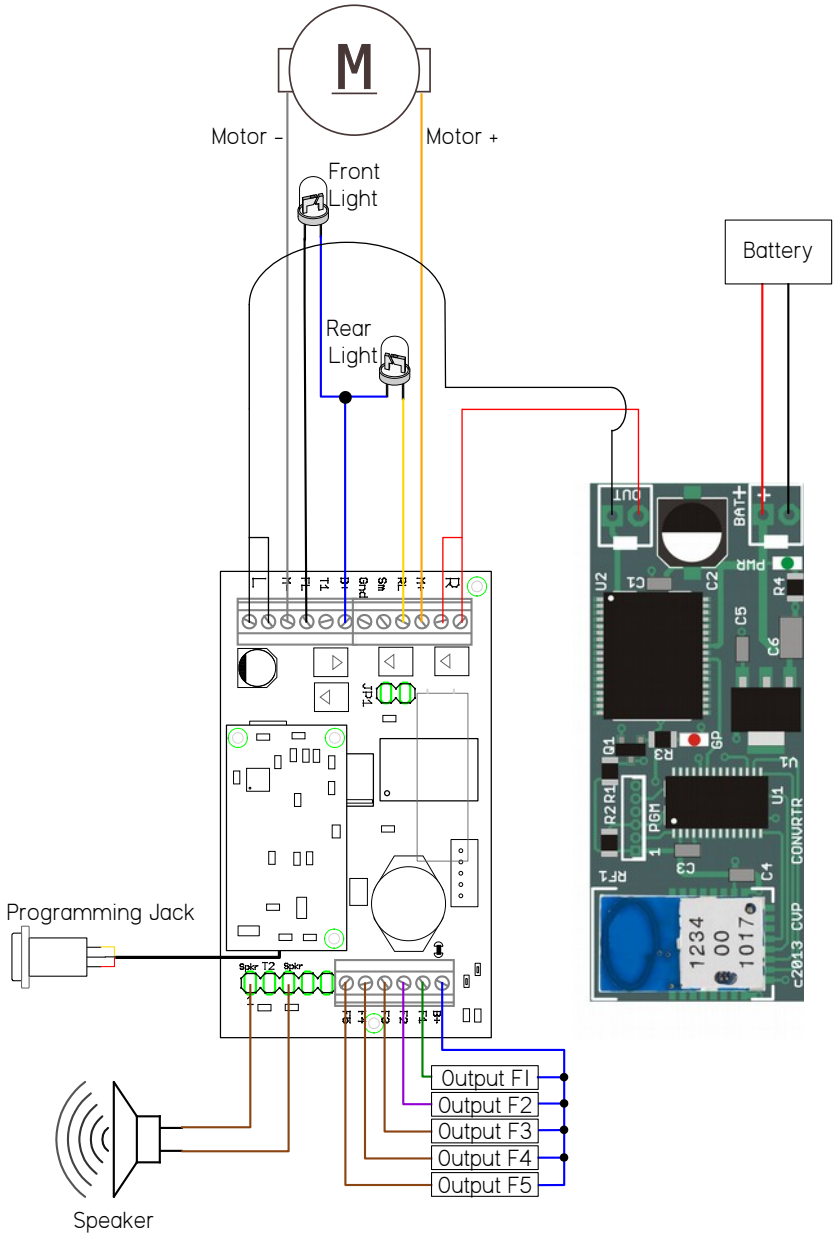

Crest Revolution DCC

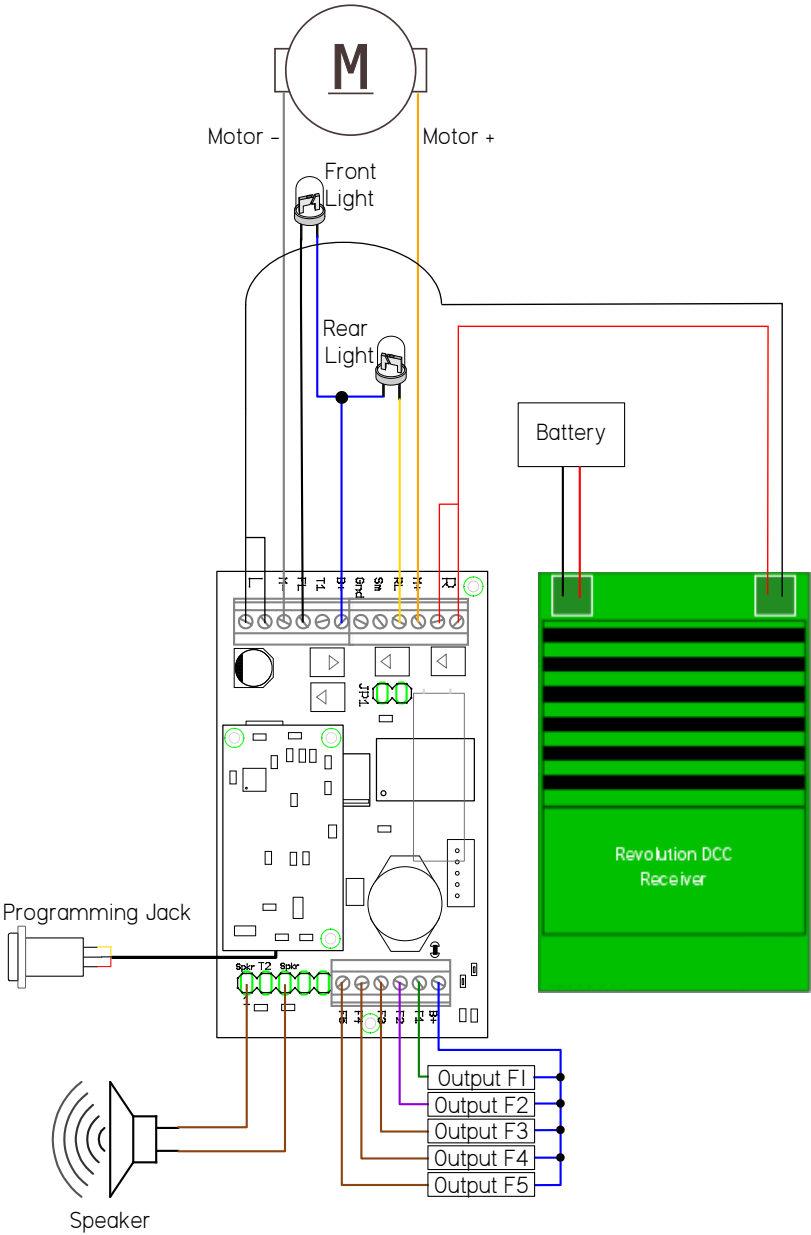

Appendix B: The Computer Interface

The Computer Interface is an optional accessory that enables complete customization of all sounds.

The Computer Interface consists of a CD and USB Interface for use with Windows 2000, XP and Vista. The CD contains software to customize sounds from the Phoenix Sound library. Connecting the USB interface to the board through the access jack allows you to download sounds for different engines and change the following:

- Individual sound volumes
- Manual vs. Programmed response for bells and whistles (horns)
- Assign sounds to terminals and DCC functions
- Adjust how often a sound plays
- Change shutdown time
- Change and modify chuff rhythm, compression and tone
- plus many other features you will discover as you familiarize yourself with the system
- Adjust Motor speed settings
- Assign effects and features to function outputs
- Programming of CVs listed as supported without a Programming track

All adjustments, upgrades and sound loading can be made through the Access Jack. You will not need to take the model apart after installation is complete.

PLEASE NOTE: THE SOFTWARE WILL RUN ON ANY PC WITH WINDOWS 95 OR NEWER. IT IS THE USB INTERFACE HARDWARE WHICH REQUIRES A MINIMUM OF WINDOWS 2000. IF YOU ARE USING THE OLDER PHOENIX SERIAL CABLE INTERFACE YOU CAN CONTINUE TO USE THE UPDATED SOFTWARE WITH YOUR EXISTING SERIAL CABLE ON WINDOWS 95/98/98SE/ME.

Warranty

The materials and operation of the SM18 supplied by Phoenix are guaranteed to perform correctly for one year when installed and operated according to the instruction manual. In the unlikely event that your system fails, please call or e-mail us so that we may evaluate the situation and save any unnecessary shipping. We prefer to pre-evaluate returns because frequently there is a simple explanation for any perceived problem you may be experiencing. Repairs and or replacements covered by this warranty are at no cost. However return shipping may be charged, especially if you return your system in an engine, tender, box car or the like. A service fee may be assessed if it is determined that the failure was not due to any Phoenix supplied components.

Phoenix Sound Systems, Inc. cannot be liable for damage to the system during shipping to our facilities due to mishandling, inadequate packaging or similar circumstances beyond our control. Please be sure to package the SM18 system in a secure, static safe manner.

Please read the handbook and any included installation notes prior to installation and operation of your system. Contact us if you have questions or are unsure about any aspect of installation or operation.

Physical modification of the circuit boards in any fashion voids this warranty. Physical modifications include but are not limited to:

- Drilling of holes in the printed circuit board for any purpose.
- Removal, replacement or modification of any components.