



Bachmann

Climax

Phoenix Sound Systems, Inc.

3514 West Liberty Road

Ann Arbor MI 48103

www.phoenixsound.com

phone: 800-651-2444

fax: 734-662-0809

e-mail: phoenixsound@phoenixsound.com

©2004-2007 Phoenix Sound Systems, Inc.

Installation Overview

Skills

Your BigSound™ Handbook, which is included in your kit, has basic information for all our sound systems. These instructions apply specifically to Bachmann's Spectrum™ Climax. Using these two manuals, you will be able to successfully install the Phoenix BigSound™ system. We have customized our standard kit with components that fit neatly although snugly into the allotted space inside the coal tender. Any sound system installation involves physically locating and securing the components (sound board, speaker, switches etc.), wiring everything together, and making sure connections to the engine are secure. Bachmann has designed the Climax to make some of these tasks easier. The small size of the coal bunker where the sound system is installed does leave a few hurdles to be overcome.

Options

AutoChuff™ Mode (Recommended)

In this mode you install track power wires to terminals 1 and 2. The system estimates the engine speed based on track voltage and then alters the chuff sounds accordingly. Hint: If you hear three toots going forward and two toots in reverse, simply switch the track power wires. As packaged, our Climax sound system is set up for AutoChuff™ operation. After many trial and error sessions, we believe the AutoChuff™ installation is the easiest, most reliable, and least frustrating. You can be up and operating in a short time.

Direct Sound Contact Wiring

Some modelers may want to take advantage of the cylinder contacts that Bachmann has supplied for the synchronization of sound. You must do some rewiring of the cylinder chuff contacts, at least with production run of the engine we have tested, for proper operation. It is possible that even after rewiring, the sound contacts may not trigger consistently. Unlike Bachmann's Shay, the sound contacts cannot be accessed for adjustment. We have included instructions for the rewiring needed.

Advanced

True-to-life operation also can be obtained by using axle magnets and a reed switch to synchronize the chuff. Additionally, some modelers may want to wire reed switches to trigger the bell and crossing whistle via track magnets.

Preparing the Tender

Opening the Tender

All your kit components will fit into the coal tender shell. The first step is to remove the tender from the floor of the truck. On the top of the coal load near the front of the tender, there are two water valve crank handles that conceal two small holes on either side of the tender. See the photograph on page 19 of

Bachmann's Operator's Manual.

These openings provide access to the Philips screws that secure the tender box to the floor. Remove the two screws but do not take off the box yet. The back end of the tender box is held in place by two plastic tabs. To avoid breaking the tabs, lift the front end of the box and carefully swing it open like a hinged lid to release the holding tab and then lift off the shell.

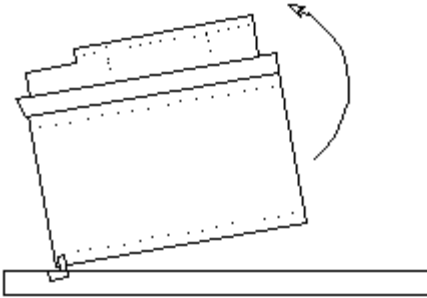

Removing The Sound Connector Board

The Bachmann sound connector board must be removed next. The wires for power and sound contacts feed through a hole at the forward edge of the tender floor. The two long wires [usually black] are the leads for track power input. The shorter wires are the cylinder sound contact wires. [These may be any color combination; In our installations they have been red and black.] You do not need the shorter wires for our recommended installation. We cut them back a little and tape them together, making sure the exposed wire ends are covered. To avoid confusion with identifying the power leads, after clipping you can tape them together with a label until you are ready to wire the board.

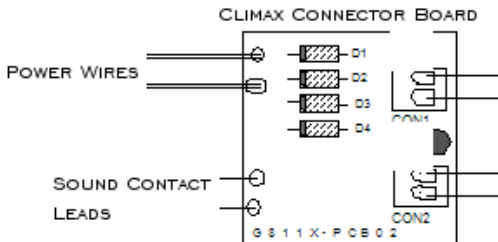

Modifying the Tender

Trim down two plastic tabs in the coal spill area inside the tender shell to accommodate the speaker. Trim enough to allow the speaker to clear this area when the shell is in place. The leading rim of the speaker extends into the corresponding coal spill area on the tender floor. After trimming the plastic tabs use clear silicone adhesive or caulk to fill in between the tender, the coal spill and the loose plastic board above it. This stiffens this part of the coal bunker and prevents rattling of these parts.

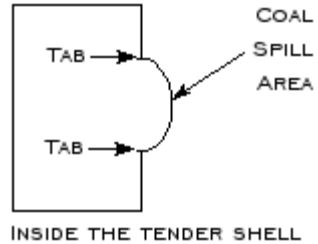

Installing the Speaker

The tender has slots cut into the floor where the speaker is installed. The speaker for the Climax has been modified to fit snugly into the opening: we have removed two of the mounting ears.

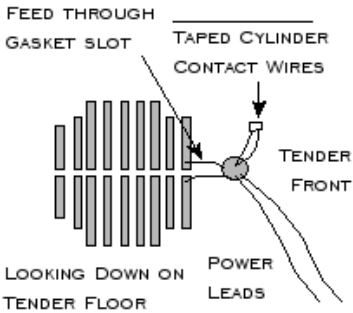

CAUTION: THE EDGES OF THE SPEAKER BASKET ARE SOMEWHAT SHARP. NOTICE THAT THERE ARE WIRES PROTRUDING THROUGH ONE OF THE SPEAKER GRILLS.

In order to prevent these wires from vibrating against the speaker cone or otherwise interfering with the installation we have included a thin fiber gasket with your kit. Cut a slot in the gasket, as shown in the diagram below. The speaker has a corresponding ring at the outer edge of the

cone. Position the gasket so the 1/4" slot that was cut is directly across from the mounting ears. Use silicone adhesive to glue the gasket to the speaker ring, verifying that the orientation is correct. The gap should align with the wires that protrude from the speaker grill.

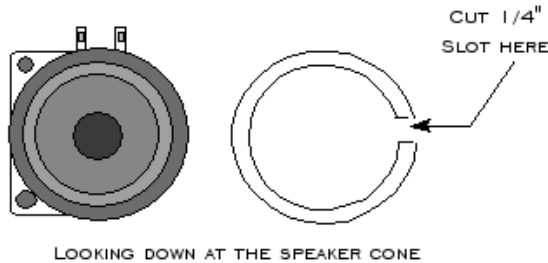

Place the speaker cone down with the mounting holes toward the back of the tender. Locate the two small square holes on the floorboard slats close to the back. Align the back edge of the speaker rim with the floorboard groove that runs through the holes. The speaker should be set so that the floorboard groove is just visible. It is imperative that the speaker is placed precisely in order for

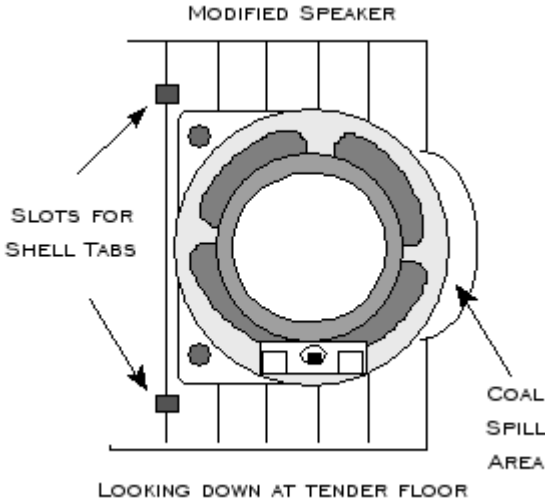

shell to fit back on the tender floor. The front edge of the speaker extends into the area where the coal spill is modeled at the forward end of the tender. Make sure that any loose pieces of the model are glued securely in place. Any extra time you spend making sure you have a good acoustic chamber is well worth the effort. Set the engine aside to allow the adhesive to set.

Installing the Volume Control Switch

The Climax has a special place for the volume control switch that makes it readily accessible. Look at the back end of the coal load at the end of the tender. There is a small water valve fitted with a lid that has a handle. The lid pulls out to expose a hole. It is difficult to place the hex nut on the shaft of the volume switch after inserting the switch through the water shaft hole. You can use an Allen wrench to position the nut and get it started then use needle nose pliers to tighten it in place. It takes a steady hand and patience.

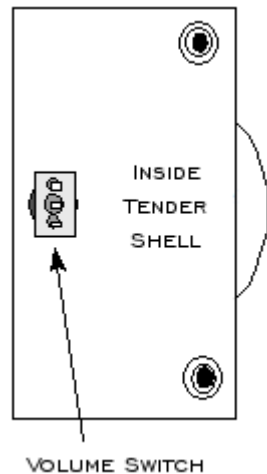

Installing the BigSound™ Board

The board is installed against the back wall inside the tender shell near the water fill hole. It fits in this spot perfectly. It may be awkward with all the wires connected to the sound board, but just take your time.

Your kit contains mounting pads that you may want to use to affix components. Regardless of what type of adhesive you use, be sure to avoid placing it on the tiny board components. A good place on the sound board is the microprocessor on the underside of the board. Holding the edges of the board, press it firmly against the back wall of the tender shell.

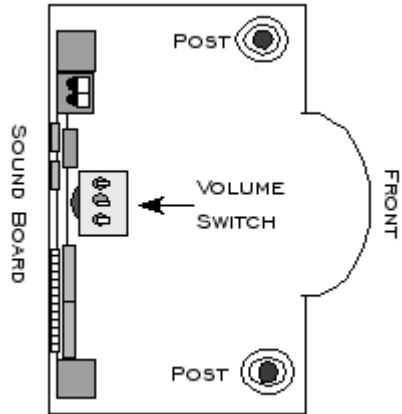

Installing the Battery

The included 3.6V battery is installed flat against the ceiling of the tender shell. The water fill hole almost touches the long edge of the battery. The second mounting pad in your kit can be used to hold the battery in place.

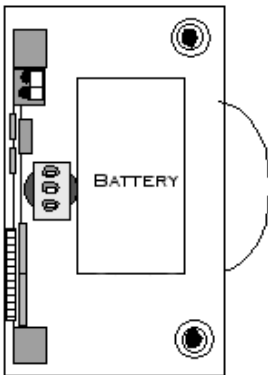

Finishing Up

Carefully place the shell over the speaker and align the tabs with the square slots at the rear of the shell just behind the speaker. Carefully swing the bunker back into place making sure that no wires are protruding from the bottom of the shell or across the screw holes at the front of the shell. Firmly seat the bunker flush with the tender floor and tighten the two long screws at the front of the tender.

Modifications for Wiring to the Cylinder Contacts

CAUTION: THIS PROCEDURE MAY VOID YOUR BACHMANN WARRANTY!

When operated “as-received,” the switches are wired in series and would not produce the chuff pattern. We have tried our rewiring method on several Climax engines with good success. Before beginning the system must be configured to derive speed from a trigger. Please see the BigSound™ Handbook for instructions on this.

1. Set the engine on your workbench with the engine facing you head on so the sketches will be correctly oriented to your work.

2. Remove the lids of the boxes that rest on top of each cylinder. Inside you can see the wires connected to metal pins along the front edge of the box.

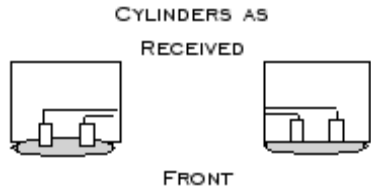

3. Inside the engineer's cylinder box, de-solder the inside wire and solder it to the outside pin, as represented by the dashed line in the sketch.

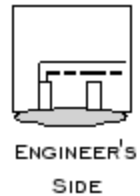

4. Drill a small hole on the inside edge of each cylinder box to accommodate the new wire that is to be added to the circuit. You should use a small gauge insulated black wire (22AWG or smaller) for this modification. You will be drilling at an angle at approximately the locations shown by the arrows below.

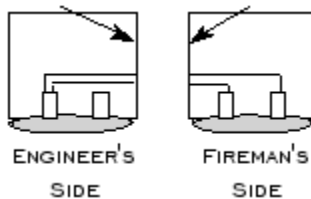

5. Cut a length of wire about 7 inches long. Strip and tin one end of the wire.

6. Thread the tinned wire through the hole on the fireman's side, across the steam boiler, and through the hole on the engineer's side.

7. Solder the wire to the inside pin of the engineer's cylinder box.

8. Cut the wire to an appropriate finished length, strip and tin the end, and solder it to the outside pin of the fireman's cylinder box.

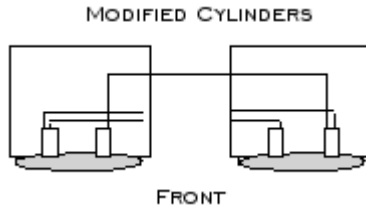

9. Once you have switch contacts that work, you will be getting two chuffs per revolution of the crankshaft. The chuffs will have an uneven pattern because of the quartering of the two flywheels. You must “un-quarter” the flywheels so that the switch contacts are made every 180° of rotation. As-received the flywheels are set 90° apart (quartered). Manually turn the flywheels on either side of the engine until they are offset 180° rather than 90°.

Reed Switches and Axle Magnets

Chuff Reed Switch (Optional)

The AutoChuff™ will be more than acceptable for most, however if some will wish to use a reed switch and axle magnets. Following is the mounting method that works well with the Climax.

In general, follow the instructions for component placement and wiring found in this manual. Mount the magnets with Silicone, Epoxy or other suitable adhesive 180° apart on the drive shaft. The chuff reed switch is mounted horizontally at the rear edge of the ash pan. Experiment a little for the best placement of the reed switch before gluing it to the bottom of the engine.

The wires from the reed switch can be routed along the underside of the cab floor to the rear end of the wiring channel. If a small portion of the rear end of the wiring channel cover is trimmed off, the reed switch wires can be easily threaded through the hole in the floor under the coal spill with the other factory wiring. In order to trim off the wiring channel cover, you will have to remove the rear power truck. This is an easy job. Just follow the instructions in your Bachmann Operator's Manual on page 28.

Bell and Whistle Reed Switches

You can install the reed switches to activate the bell and whistle via track magnets by gluing them to the brake beams on the front and rear of the back power truck. They will fit into the slot of the brake beams better if you file flats on two opposite sides of each reed switch.



CAUTION: REMOVE ONLY THE AMOUNT OF MATERIAL NECESSARY TO ALLOW THE REED SWITCH TO FIT SNUGLY INSIDE THE BRAKE BEAM. REMOVING TOO MUCH MATERIAL WILL DAMAGE THE INTERNAL PARTS OF THE REED SWITCH.

Make sure the reed switches are mounted with the tips all the way to the outer edge of the brake beam: one switch tip all the way to the right side of the engine and the other reed switch all the way to the left side. Route the wires through the same hole as the chuff reed switch wires.

These wires will fit through the hole with the factory wiring and also clear the speaker and coal bunker cover.

